

INDEX

1. GENERAL INFORMATION AND SAFETY INSTRUCTIONS.....	2
1.1 About User Guide.....	2
1.2. Meanings of Symbols Used in User Manual	2
1.3. Personal Protective Equipments.....	2
1.4. Terms of Use and Safety Information ...	3
2. MAIN INFORMATION.....	4
2.1. Vehicle Identification Plate	4
2.2. Brake Data Plate	4
2.3. VIN (Chassis) Numbers	4
2.4. Warranty and Responsibility.....	4
3.1. Brake system	5
3.1.1. Air couplings.....	5
3.1.2. Compressed Air Tanks.....	6
3.1.3. EBS Socket.....	7
3.1.4 Park Release Emergency Valve.....	7
3.1.5. Brake Chambers.....	8
3.2. Suspension System	8
3.3. Electrical System.....	8
3.3.1. 15 Pin Socet.....	9
3.3.2. 2x7 Pin Socet	9
3.4. King-Pin.....	9
3.5. Park Feet.....	10
3.5.1. Parking Legs Working Principle ...	10
<i>Support Leg and Control Arms</i>	11
3.6. Side Protection Equipment	11
3.7. Semi Trailer Axle System	11
3.7.1. Steering Axle	11
3.7.2. Retractable Axle.....	12
3.8. Wheels.....	12
3.9. Spare Wheel Holder	12
3.10. Wheel Chock	13
3.11. Kutular ve Saklama Üniteleri.....	13
3.12.1. Gooseneck Tool Cabinet.....	13
3.12.2. Steel Tool Cabinet	14
3.12.3. Fire Extinguisher Cabinet	14
3.14. Floor.....	15
3.14. Loading Ramp.....	15
3.15. Hydraulic Ramp Usage	15
3.15.1. Control of Hydraulic Sliding Ramp	16
3.15.1.1. Opening the Ramps	16
3.15.1.2. Closing the Ramps	16
3.16. Warning Signs and Rotating Warning Lamp.....	17
4. INFRASTRUCTURE AND USE COMPONENTS	17
4.1. Overview of Trailer Body Components	17
4.2. Front Panel	17
4.3. Side Panel.....	17
5. SHIPPING PROCESS.....	17
5.2. Semi-Trailer and Tractor Couplings.....	18
5.3. Things to Consider When Parking and Stopping.....	18
5.4. Important Technical Considerations...18	
5.4.1. Fire extinguisher	18
5.4.2. Wheel Chocks	19
5.4.3. Trailer Modifications	19
5.4.4. Air Leak	19
5.4.5. Environmental Issues	19
5.5. Cleaning the Vehicle	19
6. LOADING AND LOAD SECURITY	20
6.1. Safety Instructions.....	20
6.2. Using the Binding System	20
6.3. Binding Rings.....	21
6.4. Lowbed Vehicles Installation Instructions	21
6.4.1. Pre-Installation Preparations.....	21
7. INSPECTION AND MAINTENANCE	21
7.1. General information	21

7.2. Disposal of Used Materials	22
7.3. Conditions of the Place Where Service and Maintenance Are Performed	22
7.4. Periodic Maintenance and Checks	22
7.5. General Maintenance Program	22
7.6. Hydraulic and Pneumatic Hoses and Connections	23
7.7. King-Pin	23
7.8. Axle	23
7.9. Tire Inflation Pressure	23



1. GENERAL INFORMATION AND SAFETY INSTRUCTIONS

1.1 About User Guide

The usage and operating information provided in this manual has been prepared to ensure that the vehicle is used for its intended purpose and in the desired way. The instructions here contain important recommendations for you to carry out your transactions in a safe, complete and most efficient way. Complying with these instructions, warnings and recommendations will prevent accidents, reduce downtime and repair costs, and enable you to use your vehicle safely, reliably and trouble-free. Please read the operating instructions in this manual carefully and completely. The manufacturer is not responsible for any damage or deficiencies caused by failure to comply with these instructions. These instructions must be supported by local laws, rules and regulations. Please follow these instructions to prevent accidents and protect your surroundings and the environment.

The following are not allowed to be carried:

- Carrying people and live animals
- Transportations that need to be carried according to special instructions, e.g., dangerous good transportations
- Transportation of unsecured goods
- Transportation of materials that are dangerous due to their properties or that need to be carried with special equipment
- Exceeding technically and legally permissible weights of the axles or king pin load
- Exceeding of the maximum vehicle speed
- Exceeding the permissible length, width and height
- Unapproved parts like tires, accessories, spare parts and etc. by the manufacturer

- The manufacturer shall not accept any responsibility for the problems and faults that occurs that are not in compliance with the purpose of the vehicle's usage. All the risks of this issue belong to the customer.



It is necessary to keep the user manual available on the vehicle at all times.



Adhere strictly to the operating instructions when using your vehicle. When problems occur which can lead to dangerous consequences, contact the service centre immediately.

1.2. Meanings of Symbols Used in User Manual

Several warnings are available in this manual to ensure maximum safety when using your vehicle. Each warning is indicated by a special symbol. These symbols and their meanings are as follows.



The information specified by this warning symbol is very important for health and human safety. When the given information is ignored, serious damage, injuries and even death may occur.



This symbol specified in this manual indicates that critical accidents may occur when the instructions do not comply.



This symbol is used when additional information is required.

1.3. Personal Protective Equipments

Personal protective equipments serves the purpose of preventing injuries and are prevents injuries and are determined by regional regulations depending on the load carried. People who will work or perform operations on the vehicle must wear proper and appropriate protective clothing.

- Depending on the load to be carried, the eyes, ears, body, and respiratory

tract must be protected with the relevant protective equipment.

- As a rule, gloves and work shoes are always used.



It is obligatory to use appropriate personal protective equipment during the operations.



Long hair is particularly dangerous when working on the vehicle, regardless of whether it is loose or tied up, and it should be protected properly to avoid tangling.



Wearing a tie, necklace and/or dangling jewelry when working on the vehicle is strictly prohibited. They may get caught in moving parts or mechanisms and cause injuries and even death.



During the operation, protective gloves must be used. Please make sure you are using the correct type of gloves when you are working with hot parts or chemicals.



Gloves should fit snugly. Otherwise, there is a risk of them getting caught in moving parts or mechanisms.



While working on the vehicle, appropriate overalls must be worn.

- Overalls should not have pleats, buttons or external pockets and their closure system should be made in such a way that they can be opened as soon as possible in case of an emergency.
- Interior pockets should have fastenings to close them up. Cuffs should be adjusted to fit the wrist.



When working around the vehicle, a lightweight helmet approved by an accredited institution should be worn.



A hearing protective device (headsets or ear plugs) should always be used around self-propelled vehicles



Tüm bakım işlemleri sırasında koruyucu gözlük takılmalıdır.



Solunması tehlikeli maddelerle veya tozlu ortamlarda çalışırken uygun koruyucu maske kullanılmalıdır.

1.4. Terms of Use and Safety Information

- It is necessary to keep the warranty, operating and maintenance manual and other documentation about the vehicle available on the vehicle at all times.
- To prevent possible accidents and environmental pollution, follow the operating instructions and binding regulations.
- Pay attention to the safety and warning signs placed on your vehicle.
- Always keep these safety and warning signs completely visible.
- Make sure that the load carrier is secured properly.
- In case of any dangerous condition in the operation of safety, stop your vehicle immediately and inform the authorized people or institutions.
- Do not modify anything on the vehicle without a written manufacturer's approval. Your vehicles guarantee terms do not cover unapproved modifications.
- The spare parts must meet the technical requirements set forth by the manufacturer company. Only the original spare part/parts meet their requirements.

2. MAIN INFORMATION

2.1. Vehicle Identification Plate

Vehicle identification plate is located on the right side of the vehicle.

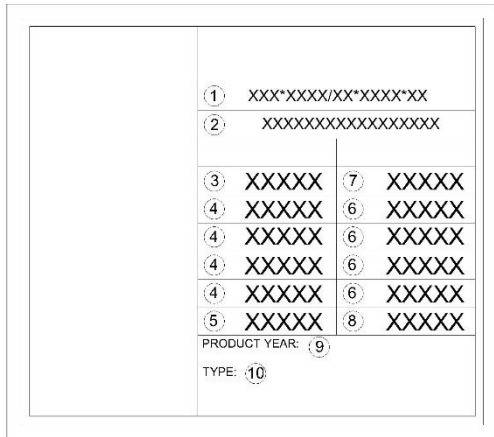

You may find these information's on this plate;

- 1.Type approval number
- 2.VIN number
- 3.Technical total axle capacity
- 4.Technical an axle capacity
- 5.Technical king pin capacity
- 6.Nationally approved an axle capacity
- 7.Nationally approved total capacity
- 8.Nationally approved king pin capacity
- 9.Product year
10. Type

2.2. Brake Data Plate

There is a brake data plate on the vehicle which is equipped with an EBS system. You may see this information on this plate.

WABCO		TREYLER EBS-E		GOVINDAKI TRAK 10 2007 - 010 01																																									
NÜKTE																																													
NK7-4																																													
NRGNKT407P1312001																																													
22948 S																																													
100 100 48/2M																																													
X																																													
All systems: IO																																													
<table border="1"> <thead> <tr> <th>Pin</th> <th>Pin1</th> <th>Pin2</th> <th>Pin3</th> <th>Pin4</th> </tr> </thead> <tbody> <tr> <td>1</td> <td>---</td> <td>---</td> <td>---</td> <td>---</td> </tr> <tr> <td>2</td> <td>SAC</td> <td>---</td> <td>---</td> <td>---</td> </tr> <tr> <td>3</td> <td>---</td> <td>RED</td> <td>---</td> <td>---</td> </tr> <tr> <td>4</td> <td>---</td> <td>---</td> <td>---</td> <td>---</td> </tr> <tr> <td>5</td> <td>---</td> <td>---</td> <td>---</td> <td>---</td> </tr> <tr> <td>6</td> <td>---</td> <td>---</td> <td>---</td> <td>---</td> </tr> <tr> <td>7</td> <td>---</td> <td>---</td> <td>---</td> <td>---</td> </tr> </tbody> </table>						Pin	Pin1	Pin2	Pin3	Pin4	1	---	---	---	---	2	SAC	---	---	---	3	---	RED	---	---	4	---	---	---	---	5	---	---	---	---	6	---	---	---	---	7	---	---	---	---
Pin	Pin1	Pin2	Pin3	Pin4																																									
1	---	---	---	---																																									
2	SAC	---	---	---																																									
3	---	RED	---	---																																									
4	---	---	---	---																																									
5	---	---	---	---																																									
6	---	---	---	---																																									
7	---	---	---	---																																									
<table border="1"> <thead> <tr> <th>Pin</th> <th>Pin1</th> <th>Pin2</th> <th>Pin3</th> <th>Pin4</th> </tr> </thead> <tbody> <tr> <td>1</td> <td>1800 0.7 3.5 10000 5.0 0.8 2</td> <td>---</td> <td>6.5</td> <td>---</td> </tr> <tr> <td>2</td> <td>1800 0.7 3.5 10000 5.0 0.8 2</td> <td>---</td> <td>6.5</td> <td>---</td> </tr> <tr> <td>3</td> <td>9000 0.7 2.5 10000 5.0 0.8 2</td> <td>---</td> <td>6.5</td> <td>---</td> </tr> <tr> <td>4</td> <td>9000 0.8 6.0 10000 5.0 0.8 1.8</td> <td>---</td> <td>6.5</td> <td>---</td> </tr> <tr> <td>5</td> <td>9000 0.8 6.0 10000 5.0 0.8 1.8</td> <td>---</td> <td>6.5</td> <td>---</td> </tr> </tbody> </table>						Pin	Pin1	Pin2	Pin3	Pin4	1	1800 0.7 3.5 10000 5.0 0.8 2	---	6.5	---	2	1800 0.7 3.5 10000 5.0 0.8 2	---	6.5	---	3	9000 0.7 2.5 10000 5.0 0.8 2	---	6.5	---	4	9000 0.8 6.0 10000 5.0 0.8 1.8	---	6.5	---	5	9000 0.8 6.0 10000 5.0 0.8 1.8	---	6.5	---										
Pin	Pin1	Pin2	Pin3	Pin4																																									
1	1800 0.7 3.5 10000 5.0 0.8 2	---	6.5	---																																									
2	1800 0.7 3.5 10000 5.0 0.8 2	---	6.5	---																																									
3	9000 0.7 2.5 10000 5.0 0.8 2	---	6.5	---																																									
4	9000 0.8 6.0 10000 5.0 0.8 1.8	---	6.5	---																																									
5	9000 0.8 6.0 10000 5.0 0.8 1.8	---	6.5	---																																									

- 1.Empty vehicle (without load)
- 2.Loaded vehicle
- 3.Axle lifting
- 4.Brake chamber data's
- 5.References
- 6.ABS Sensor Placement
- 7.Extra functions, Pin / GIO Matrix
- 8.IN/OUT-Connections

2.3. VIN (Chassis) Numbers

The VIN (chassis) number is located on the right side of the vehicle.

2.4. Warranty and Responsibility

Our trailers, onboard applications are manufactured in compliance with regulations and our quality standards. It is necessary to perform the maintenance to ensure our products always operate in the most efficient manner in compliance with our latest directives and maintenance programs. The warranty starting date is the registration date of the vehicle that is stated in the registration paper. The performance of maintenance and repair/servicing of the vehicle with the use of original spare parts by authorized service shall assure the client's warranty rights. This warranty is based upon the usage and maintenance conditions described herein and in the warranty book. Thus, it is important to read and understand this operation manual and warranty book.

It is necessary to keep the warranty, always operating and maintenance manual available on the vehicle to allow authorized service performing the servicing to see the warranty conditions and maintenance records. In the repairs made during the warranty period, the authorized service performing the repair will demand this. Purchasing one trailer or semitrailer is an important investment. For the highest return on your investment, it is necessary to comply with the manufacturer's

procedures and recommendations during the operation period of the vehicle. The information provided by the client/driver related to the warranty written in this manual shall be kept within our database.

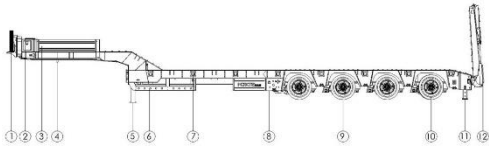

- 1- Spare Wheel Holder
- 2- Extinguisher cabinet
- 3- Gooseneck panels
- 4- King-Pin
- 5- Landing legs
- 6- Side protector
- 7- Extension bracket
- 8- Brake control panel
- 9- Tire
- 10- Self-steering axle
- 11- Rear support legs
- 12- Ramp

3.1. Brake system

3.1.1. Air couplings

The main connection between the truck and trailers is air couplings. Generally, 3 different types of air couplings are used in the trailers. These 3 types of air couplings have the same function but with different shapes and connections. There are 2 different air supply lines in the system.

- Brake Line (Yellow)
- Supply Line (Red)

Service Line: It is the pneumatic line where the pneumatic brake signal from the truck is transmitted.

Supply Line: It is the pneumatic line where the compressed air needed by the trailer is transmitted from the truck.



When the couplings are mounting/demounting, the parking brake of the truck and trailer must be

engaged.



If the brake parameters are modified, your vehicle's brake calculation might be non-suitable for regulations. Only authorized services must service to the EBS modulator.



One of the test points is the service line. As long as there is no brake signal from the truck side, this line will be empty, there will be no air at the test point. The other test point is the brake air tubes line. From this test point, it can be checked whether there is air in the vehicle.



Test Point



Supply Line (Red)

3.1.1.1. Mounting of Standard Couplings



Brake Line (Yellow)

- Slightly slide plastic covers to the upper side. Slide plastic covers to upper side.

- Be sure that sealing surfaces are clean and durable. If necessary, clean/change the air coupling.
- The coupling which comes from the truck should be pushed slightly from the upper side to the lower side and connect the coupling. Be sure that couplings are matched correctly.
- First mount service line yellow.
- Mount supply line red.

3.1.1.2. Demounting of Standart Couplings



Supply Line (Red)



Brake Line (Yellow)

- The coupling which comes from the truck should be pushed slightly from the lower side to the upper side and demount the coupling
- First demount the supply line red.
- First demount the supply line red.
- Slightly slide plastic covers to the lower side and close the plastic covers.



Driving with a non-suitable air connection is dangerous and forbidden.



Using damaged air supply parts can cause serious hazards. Torn or damaged compressed air connectors reduce the vehicle's braking performance.

3.1.2. Compressed Air Tanks

Pressured air can be stored in the air tanks. The quantities and capacities of the air tanks can be changed according to your vehicle specifications. In cold periods of the year or when the air humidity is high, the moisture in the air can be condensed and collected in the compressed air tank.

The trucks are generally fitted with air driers to prevent condensation in compressed air. The trucks are generally fitted with air driers to prevent condensation in compressed air. Even if the air driers system, the humidity in the air can be condensed. The condensed water must be drained out via the drain valve.

The water in the air tanks should be completely drained out.

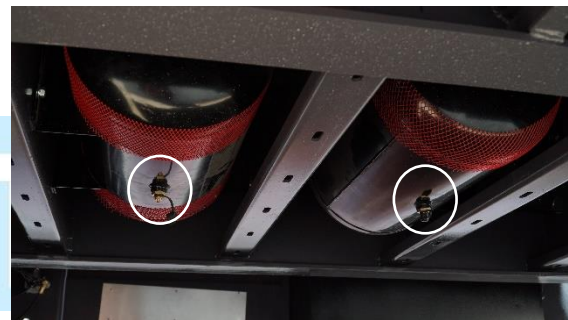

Compressed Air Tanks and Drain Valve



The water in the compressed air tank can cause corrosion problems and affect the functionality of the brake system. The frozen water in the pneumatic lines can cause the failure of the brake system.



The water in the pneumatic system should be checked more frequently in cold weather or extremely variable outside temperatures.



If the air tank pressure is certain, the EBS warning light on the truck may turn on. Be sure to check the air tank pressure.



The brakes automatically lock when the pressure in the service line (yellow coupling) drops below a certain pressure. Be sure to check the service line.

3.1.3. EBS Socket

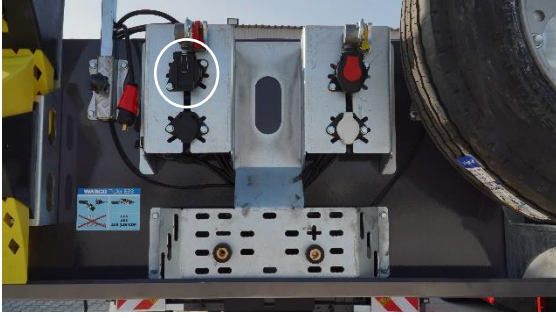

EBS Socket

Our semi-trailers are equipped with an EBS system.

EBS is an electronically controlled brake system, that is fitted with automatic load sensing braking pressure regulation (ALB) and automatic anti-skid systems (ABS/ABV).

To activate the EBS system, your truck and trailer must be equipped with an EBS system. Please mount the EBS cable that will come from the truck to the EBS socket on the trailer.

- Driving with a non-connected EBS connection is illegal.
- Drive only with an approved and well-operating EBS plug connection in accordance with regulations.
- EBS connection must be made between the truck and trailer.
- Verify the EBS plug connection with a system check.

When the truck engine is activated and during the travel, the EBS system will be checked automatically. If the truck screen is suitable/adjusted, the EBS failures will be shown with the EBS mistake lamp.

The EBS mistake lamp on the truck screen will be turned on when the ignition key is activated. If there is no failure on the EBS system, the lamp will be turned off in appr. 2 seconds.

After 7 km/hours speed, if there is a failure on the EBS system (Sensor mistake and etc.) EBS lamps will be flashed.

If the EBS lamp is activated, please contact with authorized services immediately.

Even if the truck 7 pin socket has a CAN data line, if the spiral cable used between the truck and the trailer is 5-core, it will cause the trailer EBS Modulator to not work properly. For this reason, a 7 core spiral EBS patch cable should always be used.

If you drive without EBS connectors or if there is a problem on the EBS system, the brake system will not be worked properly. This situation may cause an accident.

Römorklar, EBS sistemi için ek bir güç kaynağıyla donatılmıştır. Fren lambalarından gelen ekstra güç kaynağı sayesinde EBS konnektörü hasar gördüğünde ekstra bir güvenlik fonksiyonu devreye girecektir. EBS sistemi fren lambalarından beslenecek ve ALB (otomatik yüke duyarlı fren basıncı) ve ABV (patinaj önleme sistemi) fonksiyonları devreye girecek.

3.1.4 Park Release Emergency Valve

In general, brake control systems will be located on the driver's side. It may differ depending on the structure of your vehicle.

- Black Button: Service brake button
- Red Button: Park brake button

While driving the trailers, the red button must be pressed and the black button must be pulled.

3.1.4.1. Service Brake



Brake Button

Thanks to the service brake, maneuvers can be made without trailer air connection. The black

button can only be used without the semi-trailer air supply (red) connections on the trailer.

When you press the black button, the service brake will be disabled. When you pull the black button, the service brake will be activated.



If the service brake is used too frequently without air connection, air pressure and braking power in the system may decrease.

The service brake will be activated automatically when the air connections are removed. The service brake will be automatically disabled when the air connections are installed.



The service brake is not suitable for permanent braking of the semi-trailer. During longer waiting periods the semi-trailer must be secured with a spring parking brake and wheel chocks.

3.1.4.2. Park Brake

The spring parking brake control button is used for longer parking of semi-trailers with or without trucks on flat or sloping terrain.

It is a brake based on spring force. It does not require air for braking. When the trailer's air cylinder pressure drops below the required pressure, it is automatically activated and the brake is activated with the spring force.

When the red button is pulled, the spring parking brake will be activated. When the operator presses the red button, the spring parking brake is deactivated.

If the trailer air cylinders are empty, the brake cannot be disengaged even if the button is pressed.

This brake will not be automatically disabled. Before driving the operator must disable the brake.

3.1.5. Brake Chambers

Your vehicle can be equipped with disc or drum brake axles depending on your preference. In both types of brakes, brake chambers will be used for braking. Brake chambers will be selected according to axle type and loading capacity. Maintenance, modification or repair operations must be carried out by authorized services.

3.2. Suspension System

The lower/lift valve on the command panel can lower or raise the rear of the rigid semi-trailer for various purposes, such as performing loading operation.

The middle position of the lever allows the semi-trailer to reach the driving level regardless of the load.

You can raise the trailer by turning the control handle counterclockwise.

You can lower the trailer by turning it clockwise.



Suspension Control Arm

To fix the suspension height, you can turn the handle to the right or left according to the photo below. Before driving, the lever must be moved to the driving position.



If the trailer is used at a height that cannot be driven, the vehicle may be damaged or a height problem may arise.

3.3. Electrical System

A 15-pin socket + 2x7-pin socket is used to power the lighting system in our vehicles. You can provide electricity to your vehicle from the truck with the help of a 15-pin socket or a 2x7-pin socket.



Electrical outlets between the truck and trailer must be connected while driving.



Make sure that the truck and trailer comply with the norms/standards regarding electrical systems. Otherwise, electrical problems will occur.

3.3.1. 15 Pin Socet

This system includes stop lights, signal lights, etc. on the vehicle. It provides electricity to the electrical system. 15 pin socket connections are made according to ISO 12098. Open the protective cover and install sockets regularly. Below you can find more information about the function of the pins.

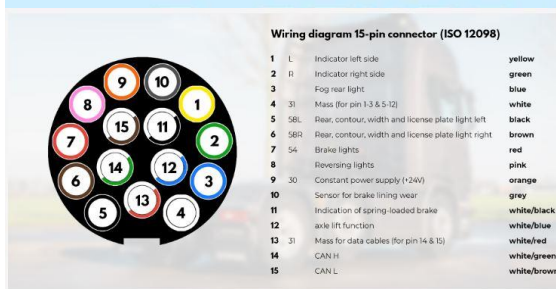

15 Pin Socet Diagram

3.3.2. 2x7 Pin Socet

This system controls the stop lights, signal lights, etc. on the vehicle. It provides electricity to the electrical system. Open the protection cover and plug in sockets regularly. Below you can find more information about the function of the pins.

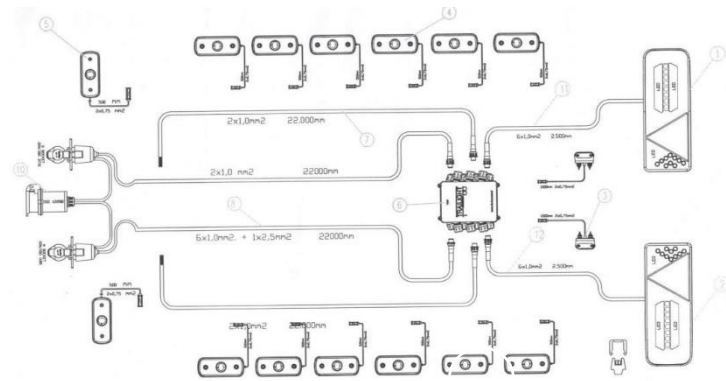

7 Pin Socet Diagram

1. Stop Group (Right)
2. Stop Group (Left)
3. Licence Plate Lamp
4. Side Marker Lamp
5. End Line Lamp
6. Electric Brain
7. Cable
8. Cable and Socet
9. Plastic Cover
10. 15 Pin Socet
11. Stop Group Cable (Right)
12. Stop Group Cable (Left)



Repairs to the electrical system should only be carried out by authorized services. Otherwise, electrical problems may occur or your vehicle may be out of warranty.



Repairs to the electrical system should only be carried out by authorized services. Otherwise, electrical problems may occur or your vehicle may be out of warranty.



If you add or remove any lamps from the vehicle, your vehicle may not comply with the regulations.

3.4. King-Pin

Your vehicle may be equipped with dual king pin slots. You can remove the bolts around the king pin and insert the king pin into the other slot. Please pay attention to the overall length of the vehicle according to country regulations and make sure the overall length complies with the regulations. Flanged king pin is used

in the vehicle. Therefore, the king pin can be easily replaced.

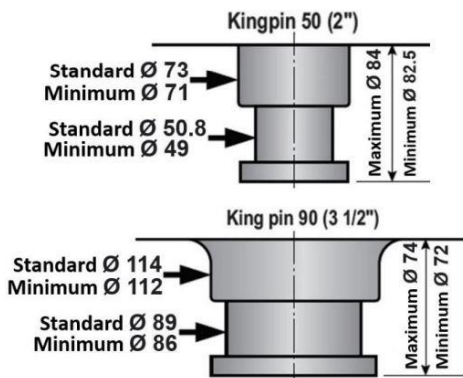

Injuries may occur if you mate the truck and trailer with a different diameter kingpin.

! If the wear on the king pin is greater than 2 mm, the king pin needs to be replaced.

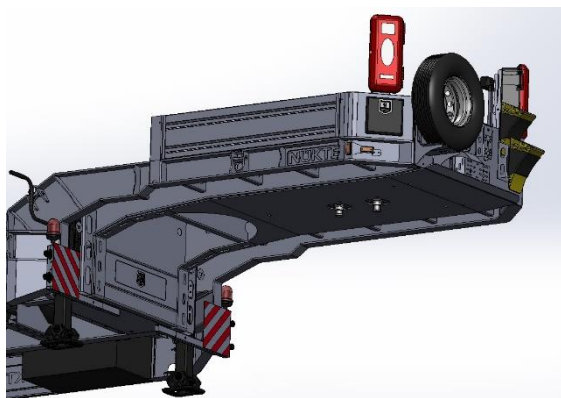

King-Pin (Representative)

3.5. Park Feet

There are parking legs behind the gooseneck of the vehicle so that your vehicle can stay parked without towing.

3.5.1. Parking Legs Working Principle



Parking Lengs

! The landing gear is removed from the swingarm holder and positioned perpendicular to the vehicle.

Low Speed: Raises/lowers at low speed when the lever is rotated to the fully depressed position.

High Speed: Performs high speed lifting/lowering when the arm is in the fully extended position. The position is used to quickly lower the gear until the foot (plates) touch the ground during the process of separating the semi-trailer from the tractor, or to quickly raise the gear after coupling the semi-trailer to the tractor.

! In all cases, secure the semi-trailer against tipping over with correctly positioned chocks. If the vehicle is not properly secured, damage to the landing gear or vehicle may occur. This may void your vehicle's warranty.

! If the semi-trailer is loaded/unloaded without being paired with a tractor, the front or rear of the vehicle may lift. Serious accidents and damage may occur. Therefore, the semi-trailer must be paired with the tractor during loading/unloading.

! If the tow truck sets off while the vehicle is loaded, make sure that the load is distributed homogeneously within the vehicle. Otherwise, the front or rear of the vehicle may lift due to the center of gravity and cause serious accidents.

To protect the landing gear;

- Only disconnect the semi-trailer from the tractor with the support legs in the middle position.
- If the semi-trailer not attached to the tractor is parked for a long time, make sure the air suspension is lowered and adjust the landing gear afterwards. This keeps the loading bay flat.



Make sure the landing gear is down (at its highest) before starting to drive.

3.5.2.1 Hidrolik Arka Destek Ayağı

The hydraulic rear support leg is used for the same purpose as the rear mechanical leg. Its length can be adjusted with the hydraulic control panel. Its use on the vehicle is provided by the start button and control lever located on the right rear of the vehicle.



Support Leg and Control Arms

3.6. Side Protection Equipment

The lowbed vehicle has fixed side protection equipment in accordance with the regulations.



Side Protection Frame

3.7. Semi Trailer Axle System

Axles with disc or drum type brake mechanisms are used in your vehicles. Semi-trailer axles can only be loaded with the maximum legally permissible axle load stated on the vehicle identification plate. The user is responsible for the use and maintenance of the trailer in accordance with its purpose and capacity. The proper functioning of the semi-trailer brake system depends on the semi-trailer being used with the same system and/or compatible tractor. For this reason, the buyer is required to market the brake adjustment to the authorized service of the

towing company with which these semi-trailers will be paired. If your vehicle is paired and used with non-adjustable or non-adjustable tractors, malfunctions and damages that may occur in the brake system or the entire tractor and semi-trailer are excluded from liability and belong to the buyer.



Akslarınız hakkında daha detaylı bilgi için lütfen teslimat sırasında size verilen üretici kılavuzuna bakınız.



Aksların üretici kılavuzunda belirtilen şartların dışında kullanılması veya bakımlarının aksatılması durumunda aracınız garanti dışı kalabilir.



Kampanalar çok sıcakken asla park frenini çekmeyin.

3.7.1. Steering Axle

Your vehicle is equipped with a steer axle to increase maneuverability when driving forward. This type of axle is usually the rear axle of the vehicle and has a locking mechanism.

The mobility of the self-steering axle vehicle is different from standard vehicles. Additionally, there will be differences in the maneuverability of the vehicle when the steering axle is locked and unlocked. Therefore you should be careful while driving.

If you want to lock the axle, make sure the swing axle is in the straight position and turn off the switch. Axle is in locked position.



Locked Position



It is dangerous to reverse with the steer axle unlocked. The semi-trailer

can be separated from the tractor. Make sure the swing axle is locked before reversing.

3.7.2. Retractable Axle

The axle lifting feature is offered optionally in different quantities and locations in your vehicle. It is provided with automatic or manual options according to the customer's request. Thanks to this feature, tire wear is minimized and a more balanced load distribution on the tractor can be achieved. The EBS connection must be active for the axle lift to work.

In the automatic axle lifting system, some axles can be lifted automatically when certain conditions are met:

- When the specified speed is exceeded while EBS is active,
- If the load on the axles is less than the maximum permissible axle load,

The operator may need to intervene manually in the axle lifting operation using a traction aid or maneuvering aid.



In order for the traction assist (lifting the axle) to be activated, the vehicle must move slower than 30 km/h and the technical capacity of the remaining axles must not exceed 30%.

If your vehicle has an optional axle lift feature from the tractor cabin, it is possible to lower/raise the axle lift manually with the spring button installed in the tractor cabin.

Due to this feature, your tractor must be adjusted accordingly.



Your vehicle may be out of regulation as a result of interfering with the axle lifting parameters. For this reason, the EBS modulator should not be intervened except by authorized services.

3.8. Wheels

When choosing semi-trailer tires, care should be taken to ensure that the tire has the appropriate carrying capacity.

The manufacturer offers tires suitable for a variety of uses, such as high-road use, off-road use or mixed use. Among the tires suitable for your intended use, tires with a low decibel value and as close as possible to Class A should be preferred in terms of braking ability and fuel efficiency on wet roads, according to the EU tire label values.

For single-wheeled vehicles, tires must be properly matched according to their diameter. The tread depths of the tires should not differ by more than 5 mm. Additionally, depending on the structure and type of vehicle, newly retreaded tires and partially worn tires should not be used side by side. Otherwise, driving safety will be eliminated. Even though the tread depth seems to be the same in these types of tires, it should be concluded that the tire radii are different and tires with a radius difference exceeding 10 mm should not be used side by side.

The mismatch causes the larger tire to deform excessively by carrying too much load. In this case, wear accelerates and there is a danger of premature tire wear. This should also be taken into account when radial and bias ply tires are used side by side.



In some countries, the use of seasonal M+S (Mud and Snow) or 3PMSF (3 Peak Snowflakes) may be mandatory. This etc. in the country where the vehicle is used. Tire regulations must be observed.



Serious accidents may occur if unsuitable or worn tires are used.

3.9. Spare Wheel Holder

1 spare wheel holder is provided in lowbed standard vehicles.



Be sure to place the necessary warning signs and take safety precautions during tire change.



Driving with inadequately secured spare tire(s) may cause traffic

accidents.



Since tires are heavy parts, pay attention to ergonomics and occupational health and safety rules when changing tires. There is a risk of pinching, falling and cutting.



Carry only that type of tire in the carrier for which tire the spare tire carrier is designed. Follow rules and regulations when removing/installing or servicing the spare tire or spare tire carrier.

3.10. Wheel Chock

There are two chocks in the vehicle that are fixed with a holder.



Wheel Chock



The vehicle must be secured with wedges when parked on a slope, during loading/unloading operations or when parked without a tow truck.



Place chocks only on wheels on fixed axles; never use idle/steer axles.

3.11. Kutular ve Saklama Üniteleri



Begin driving after ensuring that cabinets and storage units are completely closed and the items inside are secured and secure. Falling parts may cause traffic accidents.

Ensure that necessary safety precautions are taken when using cabinets and storage units.

Ensure that necessary safety precautions are taken when using cabinets and storage units.

3.12.1. Gooseneck Tool Cabinet

It is used for storing tools. Usually mounted on the driver's side of the vehicle.

There is 1 tool cabinet on the right, 1 on the left and one on the top in the Deveboyunu area.



Gooseneck Tool Cabinet (Open/Right-Left)

Gooseneck Tool Cabinet (Close/Right/Left)





Gooseneck Tool Cabinet (Closed/Top)



Gooseneck Tool Cabinet (Opened/Top)

3.12.2. Steel Tool Cabinet

There is one tool chest on the right and one on the left in the platform section of your vehicle.



Steel Tool Cabinet (Closed)



Steel Tool Cabinet (Opened)

3.12.3. Fire Extinguisher Cabinet

Fire extinguisher cabinets are used to protect fire extinguishers from the external environment.



Fire extinguishers should be maintained regularly and expiration dates should be paid attention to.

Opening the cabinet door:

- Open the two plastic latches holding the cover.
- Lift the latch up and back and open the latch to open the cover. Open the fire extinguisher's fastener and take the fire extinguisher.



Fire Cabinet (Open)

Dolap kapağının kapanması:

- Position and secure the fire extinguisher.
- First, close the lid and close the latch on the lid.
- Lock the latch to tighten the cover.



Fire Cabinet (Closed)

3.14. Floor

For lowbed vehicles, it varies according to customer request:

- Wooden Flooring
- Grid Flooring

Hard wooden floor was used on the floor. There is a plate at the top of the wheels in the axle area. It is fixed to the chassis by applying a base screw to the wooden floor.

There is a grid floor made of galvanized steel material. There is a checkered sheet metal on the top of the wheels in the axle area.

3.14. Loading Ramp

Ramps vary according to their length, width, base type, operation and use.

Ramp types:

- Ramp operated by hydraulic system
- Portable ramp

There are two different movements in ramps:

- Movement of the ramp up and down.
- Right and left movement of the ramp.

Ramps operated by hydraulic system vary according to customer request; Ramp type, ramp capacity, ramp floor type, etc. The up and down movement of the hydraulic ramps is done with the help of the hydraulic system.

Lateral movements are divided into two types, mechanical and hydraulic, according to customer request.



Take safety precautions when the ramp is operated.



Do not move the load to the right or left while there is a load on the ramp. In this case, your ramp may be deformed/damaged since all the load will be on your ramp.



If the installation is not carried out according to the installation instructions, your vehicle may be out of warranty.



Loading Ramp (Close)



Portable Ramp



When loading the Portable Ramp, make sure that the ramp is fully on the ground.

3.15. Hydraulic Ramp Usage

There is a power unit (Powerpack) in your vehicle for the hydraulic ramp to operate. A

cable connection must be made between the towing vehicle and the trailer.

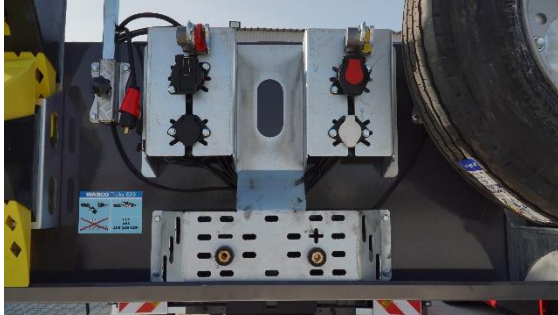

Power Unit Socket Panel





Power Unit Connection Cable

Remove the chain assembly from the ramp when loading and unloading from either ramp.



Safety Chain

 The chain can cause damage and injury only when removed from the platform and suspended over the ramp.

 Before removing the ramp padlocks, make sure that there is no oil leakage from the ramp lowering and lifting cylinders and connection fittings.

Rampaları yük seviyesinde sağa ve sola kaydırabilmek için rampa kaydırma kilidini açın.



Ramp Lock

 Before using the ramps, make sure the rear outriggers are extended and lowered.

 Loading without lowering the support legs and fully pressing the ground may damage your vehicle. This may put your vehicle out of warranty.

3.15.1. Control of Hydraulic Sliding Ramp



*Control Levers and Power Unit Button
(Representative)*

3.15.1.1. Opening the Ramps

Press and hold the power button to move your vehicle's ramps. Lower lever number 4. Make sure the support legs are firmly on the ground. Push lever number 1 downwards. In this way, your ramp will move downwards. If you have a 2-stage ramp leg (optional), lower the lever number 2 before your ramp reaches the ground and open your 2nd stage ramp. Move lever 3 downwards to move your ramp legs left or right.

3.15.1.2. Closing the Ramps

Press and hold the power button to move your vehicle's ramps. Lift lever number 4 up. Push lever number 1 upwards. In this way, your ramp will move upwards. If you have a 2-stage ramp leg (optional), lift the number 2 lever up

and close your 2nd stage ramp before your ramp closes. Move lever 3 downwards to move your ramp legs left or right.



Movement of ramp control arms varies depending on options.



Do not use ramps for loads exceeding the load capacity.

3.16. Warning Signs and Rotating Warning Lamp

It is used to warn other drivers if the loads carried are wider than the trailer. To use expansion tags, loosen the 2 thumbscrews on the brackets. Extend the expansion arm as far as desired, then slide the expansion arm until the holes in the expansion arm profile match the mounting bracket. When the holes match, tighten the wing bolt that matches this hole. Then tighten the lock nut on this bolt for security. In this way you fix the expansion arm. Then tighten the other wing bolt and tighten the counter nut on it. This way you reduce vibration by freeing up the expansion arm.



In case of malfunction, only authorized persons should intervene.



Check regularly that the lamps are working.



Warning Sign (Front of Vehicle)



Warning Sign (Rear of Vehicle)

4. INFRASTRUCTURE AND USE COMPONENTS

4.1. Overview of Trailer Body Components

The superstructure can be optionally changed in line with customer requests.

4.2. Front Panel

Ön panel galvaniz kaplamalı çelik malzemeden yapılmıştır. Yükseklik müşteri isteğine göre değişiklik gösterebilir.

4.3. Side Panel

The Deveboynu area is surrounded by covers made of steel profiles. These covers and the poles on which the covers are placed can be removed from the vehicle when necessary. Length, width and heights may vary according to customer request.



Optionally, an aluminum cover can be requested.

5. SHIPPING PROCESS

To couple the semitrailer to the tractor, follow these steps:

- Check whether the king-pin and couplings are normal. Make sure that the fifth wheel, upper link plate and king pin have sufficient grease and are free of dust and contaminants to prevent damage during coupling.
- Lower the height of the tractor rear suspension airbags until they are located in the king pin section of the semi-trailer.

- Set the 5th wheel locking system on the tractor to the "On" position.
- Adjust the height of the semi-trailer to attach it to the tractor. The height of the semi-trailer can be adjusted with mechanical landing gear. Prevent the semi-trailer from moving by using the parking brake. For safety, block the wheels behind them.
- Move the tractor until the fifth wheel touches the upper hitch plate of the semi-trailer and slowly move backwards at the same level. The fifth wheel will slide smoothly under the upper link plate and enter the shoes of the king-pin and automatically lock with the intensity of the impact.
- Raise the semi-trailer's lower legs and replace the lower legs lever.
- Hava, elektrik ve EBS kablo ve hortumlarını çekiciden üzerindeki yerlerine bağlayınız. Tüm fonksiyonların düzgün çalıştığından emin olun.
- If the vehicle has a parking brake, release the parking brake.



If your vehicle is used incorrectly at the 5th wheel height, malfunctions may occur in the vehicle. You may have a height problem. The vehicle must be driven at the correct fifth wheel height.

5.2. Semi-Trailer and Tractor Couplings

To separate the semi-trailer from the tractor, follow these steps:

- If the vehicle has service type brake chambers, apply the parking brake after checking the brake drum. Never apply the parking brake when the brake drums are very hot. (The drum may crack.)
- If the vehicle has handbrake type brakes, put chocks in front of the vehicle. Pull the parking brake.
- Disconnect the brake air lines and the brake will be applied automatically. Disconnect the semi-trailer electrical connections.

- Lower the mechanical landing gear of the semi-trailer (use high speed). When the mechanical landing gear legs or wheels touch the ground, move the mechanical landing gear crank handle to the low speed position to lift the semi-trailer.
- Unlock the fifth wheel. Separate the tractor from the semi-trailer by approximately 500 mm by slowly moving the tractor forward. Lower the level of the tractor's rear suspension airbags and release the bottom of the semi-trailer.



To ensure that the king pin is properly locked, engage first gear of the tractor and press the accelerator pedal, as you slowly release the clutch you will feel the tractor trying to move the semi-trailer, this indicates: The coupling is done properly. This coupling must be checked carefully while driving to avoid accidental separation of the semi-trailer from the tractor.

5.3. Things to Consider When Parking and Stopping

Unintentional trailer movements at night, unstable stance and inadequate safety can cause serious accidents and injuries.

- Use the parking brake and wheel chocks when stopping.
- If you are going to park your vehicle in public traffic, you must use the necessary marking plate in accordance with legal regulations.

5.4. Important Technical Considerations

5.4.1. Fire extinguisher

Please check fire extinguishers periodically every year and refill if necessary. If fire extinguishers are used, fill them immediately.

Precautions to be taken in case of fire:

Some sealants emit gases when burned, and these gases can become corrosive acids when in contact with water. Therefore, never touch fire extinguisher liquid accumulations without wearing protective gloves.

5.4.2. Wheel Chocks

When parking, hold the wheel chocks in place and place them under the wheels. Don't forget to remove the wheel chocks before hitting the road.

5.4.3. Trailer Modifications

Repairs and modifications should only be carried out by authorized services. Otherwise, your vehicle may be out of warranty.

5.4.4. Air Leak

If the air pressure in the air tubes drops immediately when the engine stops, it means there is a leak in the pneumatic system. In such a case, contact the nearest authorized service. Air leakage not only affects the safety of the braking system, but also negatively affects the load-bearing capacity of the airbags.

5.4.5. Environmental Issues

All forms of pollution pose a threat to the environment. To keep contamination to a minimum, collect waste materials carefully and dispose of them in accordance with your country's regulations.

Health and safety

- Keep sparks and fire away from the battery. The battery emits explosive gas that may cause an explosion.
- Wear safety glasses and rubber gloves when working on the battery, otherwise the battery hand control may cause burns and serious damage to your eyes, including blindness.
- Do not allow children to use the battery under any circumstances. Make sure everyone handling the battery is aware of its proper use and hazards.
- Be very careful with the battery electrolyte as it contains diluted sulfuric acid. Contact with skin and eyes may cause burns or vision loss.
- Read and understand this manual carefully before working on the battery. Failure to

follow instructions may result in injury or damage to the vehicle.

- Do not use the battery if the electrolyte level is at or below the recommended level. Using a battery with low electrolyte level may cause explosion and serious injury.

If your vehicle contains waste oil and materials that come into contact with waste oil, pay attention to the following warnings.

When disposing of products/wastes such as used oil and hydraulic oil, do not throw them into canals, sewers, landfills or soil. This is against the legislation of all countries.

This rule also applies to empty containers that come into contact with oil, chemicals and cleaning cloth waste. Take these wastes to the relevant authorities or the most appropriate service point for disposal.

If your vehicle's tire has expired;

End-of-life tires[®] must be disposed of in accordance with regulations. To do this, take your expired tire to the trailer authorities or appropriate service points.

If you carry hazardous chemicals in your vehicle;

In case of accident or emergency that may occur during transportation, act in accordance with the Written Instructions of ADR Legislation. From a trailer's lifespan perspective, it is important to recycle the end-of-life vehicle in an environmentally friendly manner. Most of the trailer consists of recyclable materials. For the recycling of expired trailers, contact the approved company and appropriate service.

5.5. Cleaning the Vehicle

Before you start cleaning the vehicle, check the hub and axle lifter for leaks. These may not appear after the cleaning process is completed. When washing with pressure water, pay particular attention to the following:

- Do not point the hose nozzle directly at the seals while washing with pressurized water.
- Do not apply pressurized water to the electrical parts and connections of the vehicle.
- In order to avoid damaging the vehicle logo and paint, the vehicle should be washed at a minimum distance of 1 m and at a maximum angle of 45 degrees, using a pressure washing machine with a maximum of 240 bar.
- After cleaning the vehicle, carefully lubricate the lubrication points with a grease gun. This is important to prevent dirt and moisture from entering various parts of the vehicle.
- Clean the interior and exterior of the vehicle every time you return.



Do not use flammable liquids or toxic substances for cleaning.

6. LOADING AND LOAD SECURITY

6.1. Safety Instructions



Accident hazards arising from unprofessional loading, unloading and load securing operations.

Make sure the cargo is properly distributed and complies with all laws, rules and regulations. Check loading limits, total weight and axle load capacities. Do not exceed the weight limits stated in the user manual and identification plate. To comply with all national/international laws, rules and regulations regarding loading and occupational safety.

- Place cargo as close to the floor of the loading area as possible. The load's center of gravity must always be on the center line of the vehicle. Existence of all regulations and laws regarding load security.
- When designing all vehicles, except certain vehicles, it is assumed that the load will be distributed equally on the load-bearing surface and calculations are made accordingly. Therefore, up to the maximum carrying capacity of your vehicle, the load must be

distributed in a way that ensures equal weights per unit area on the used transport area. When point loads are to be transported, a rigid distribution platform should be placed under the load to place the load up to the unit area capacity of the semi-trailer.



When loading with a crane or forklift, make sure that there is no one under or around the load.



Do not exceed the maximum allowable height during the installation process. Loading within the specified loading limits will help you avoid traffic accidents.



Fastening the load to the vehicle surface with a tool other than authorized equipment is dangerous and prohibited.

6.2. Using the Binding System

When installing fastening systems, try to apply the highest tension force possible. The higher the tensile strength, the less fastening systems are needed.



Always use at least two tie-down systems. This will ensure that the load is secured more evenly.

NÜKTE does not accept any responsibility for the fastening of the load.

Make sure you distribute the load in accordance with all laws, rules and regulations.

During the loading process, consider the loading limits, total weight and load capacities of the axles.

Make sure that you load in accordance with the rules and laws of all countries where you will use the vehicle. Loading schemes vary depending on vehicle type and customer demands.

Axle loads of tractor/semi-trailer combinations can vary widely depending on different loading conditions.

Observe the permissible axle loads specified in the user manual or the axle manufacturer's manual. If in doubt, have your axle loads checked at a suitable weighing station.

Unsecured loads can slide or roll on their surfaces. Therefore, before setting off, secure loads effectively against slipping and tipping over.

6.3. Binding Rings

There are lashing rings on the platform and on the sides to secure the load.
The load capacities of the rings vary depending on the configuration of the selected vehicle.



Uygun şekilde sabitlenmemiş bir yük insanlara, hayvanlara veya eşyalara ciddi zarar verebilir.



Binding Ring (Closed)



Binding Ring (Open)

6.4. Lowbed Vehicles Installation Instructions

6.4.1. Pre-Installation Preparations

- When loading the trailer, do not exceed the values specified in the transport document.
- When loading the trailer, load it balancedly, taking into account the king pin and axle capacities specified in the transport document.

6.4.1.1. Kurulum Öncesi Kontroller

• Check that the electrical and brake connections on the truck and trailer are made. Make sure the electrical, brake and suspension systems on the trailer are working.

- Plan how the loading should be done by giving information about the weight, center of gravity, width and height of the load.

6.4.1.2. General Information

- Check kingpin connections between trailer and truck hitches before loading.
- Make sure the trailer and truck parking brakes are on.
- Use wheel chocks to prevent the trailer from sliding.
- Do not load the trailer without the truck attached.

6.4.1.3. Protection of Vehicles in Preparation and Loading Status

Remove greasy and coarse dirt from the loading area.

- The load should be placed in the slots of the lashing rings on the platform where the load can hit.

6.4.2. Load Position

- Load it in a way that does not pose a danger, taking into account the values specified in the technical document.
- If the load to be transported does not comply with the specified loading conditions, make carrying stands under it to spread the load across the vehicle.
- Place the load symmetrically relative to the vehicle axis.

7. INSPECTION AND MAINTENANCE

7.1. General information

All instructions apply to standard vehicle maintenance, lubrication, inspection and standard settings.

7.2. Disposal of Used Materials

In case of parts or oil replacement during maintenance operations, old materials (oils, filters, etc.) must be disposed of in accordance with environmental regulations.



Used oil and oil filters contain substances that are harmful to the environment. After replacing the contaminated parts, contact an authorized waste recycling center to dispose of used oil filters and oils in accordance with the environment and current legislation.

7.3. Conditions of the Place Where Service and Maintenance Are Performed



All operations described in this section should only be performed by trained personnel.

It is strictly forbidden for unauthorized persons, other than maintenance personnel, to be near the vehicle during maintenance operations.

- Since exhaust gas is hazardous, ensure adequate ventilation when the power unit or engine is operating in a confined space.
- Unless otherwise stated, maintenance operations should be performed with the power unit turned off.
- You must properly support the vehicle when performing maintenance on the hydraulic lifting system.
- You should always use NÜKTE spare parts.
- Always use clean oil and grease, also make sure the oil containers are clean.
- Always check the oil in a suitable place and change if necessary. Make sure there is no dirt mixed into the oil.
- It is recommended to wash the vehicle before any periodic maintenance.

7.4. Periodic Maintenance and Checks

- Proper lubrication and maintenance are essential to prevent problems in advance and ensure long vehicle life.
- Long vehicle life and reduced operating costs will more than cover the time and costs required for periodic maintenance.
- If the vehicle is used in harsh environmental and operating conditions, the intervals for the maintenance operations described in this manual should be kept shorter.

7.5. General Maintenance Program New Semi Trailer

Tightness of wheel nuts;

- After delivery,
- After 50 km,
- After 200 kilometers
- Must be checked after 1500 km

After reaching this mileage, it is necessary to check the tightness of the suspension nuts, axle nuts and wheel hub clearance.

Semi-Trailers in Normal Use

Specific maintenance intervals should be determined based on experience and actual usage conditions. The following maintenance schedule is valid under reasonable vehicle use and normal operating conditions.

Weekly Maintenance Work

- Check the steering wheel.
- Check the fifth wheel pin.
- Check if the brake system is working properly.
- Check tire pressures.
- Check the tightness of the wheel nuts.
- Check the tightness of the wheel nuts.
- Check that the grease reaches the points lubricated by the central lubrication system,

that the system is working properly and that the pump tank is full of grease (with a central lubrication system). for vehicles) check.

- Check the hydraulic oil level in the tank.

Monthly Maintenance Work

- The hydraulic system oil should be changed after the first one or two months of use of the semi-trailer. Hydraulic oil changed after the first two months of use can be reused if it is carefully filtered.

- Check the wear of the brake pads.
- Adjust the brakes.
- Check height adjuster adjustment.
- Check alignment of axles.
- Check the pressure values provided by the brake control.

Quarterly Maintenance Work

- Clean the filter element of the Yellow and Red connecting heads.
- Check the suspension system for wear, oil leaks and damage.
- Check for leaks in the brake system (with the service brake activated).
- Check for air leaks in the air suspension.
- Check the airbags for damage.
- Check the roller surface for contamination, clean if necessary.
- Check the parabolic springs for wear, scratches and corrosion.
- Check tire wear.

Maintenance Work Every Six Months

- Check axles.
- Check bearing clearances.
- Check pneumatic system components.
- Check hydraulic system components.

Annual Maintenance Work

- Check their suspension (clearance adjustment).
- Check the brake chambers.
- Change the hydraulic oil used in the system once a year. (In cases where contamination is detected earlier in the hydraulic system oil checks, the period of 1 year should not be waited for hydraulic oil change.)

7.6. Hydraulic and Pneumatic Hoses and Connections

Check all connections after the first month.

- Check the fittings again after 6 months.
- These operations should be repeated every time there is oil or air leakage from the fittings
- If oil leakage is detected in the connections, tank levels should be checked.
- Replace the hoses every three years to ensure maximum machine safety.

7.7. King-Pin

Please refer to the manufacturer's manual for king-pin usage, maintenance, disassembly and installation instructions.

7.8. Axle

Refer to the axle manufacturer's manual for detailed information on wheel tightening torques.

7.9. Tire Inflation Pressure



Tire pressure should be checked when the tires are "cold" after the vehicle has been parked for several hours.

Never deflate a tire when it is hot.

Insufficient pressure between the two installed tires will cause abnormal tire wear and overheating of the parts in contact.

For normal tire wear, tire inflation values should be checked regularly and pressure values should be equal in all tires.